

INSTALLATION INSTRUCTIONS:

Quick Ratio Power Steering Conversion, 66-77 Bronco

PART #3226B



865.938.6696 www.dufftuff.com
6609 Bronco Ln. Knoxville, TN 37921

CONTENTS:

1	Power Steering Box	4	1/2" Flat Washers
1	Custom Saginaw Steering Pump	4	1/2" NC Nyloc Nuts
1	Pump Mounting Bracket	1	7/16" x 7" NC All Thread*
1	Pump Adjusting Bracket	2	7/16" NC Nuts
1	Steering U-joint	2	3/8" Flat Washers
1	Pressure Hose	1	10mm 1.5x35mm Gr 8 Bolt
1	Return Hose	1	10mm 1.5x40mm Gr 8 Bolt
1	Belt	1	10mm 1.5x40mm Flat Head Socket Screw
1	Pulley (pre-installed on pump)		
1	3/8" Hose Clamp		
1	3/8" x 1" NC Gr 5 Bolt		
4	1/2"-13 x 4.5" Gr 5 Bolt		

1/4 5/25

*Some cylinder heads may require replacing this with 3/8" all thread. It, as well as the corresponding nuts, can be obtained at most hardware stores if needed.

Please read all instructions before beginning. Note the vehicle must be equipped with a double groove crank and water pump pulley for installation.

Important: This conversion is only compatible with 289/302(5.0L) & 351W(5.8L) Windsor based v8s. It is not compatible with any other engine.

Preparation and removal of old system:

1. Block tires so the vehicle will not roll and disconnect negative side of the battery.

2. Remove the nut and pitman arm from the steering box on the vehicle. It will likely be necessary to use a pitman arm puller to do this.

3. Loosen the clamp on the side of the u-joint connecting the steering shaft to the steering box. Then, loosen the circular clamp at the end of the steering column (near the firewall) and pull the steering shaft up the column until the end of the u-joint is even with the oil filter. Use a pair of locking pliers to secure the shaft by placing them under the steering wheel. For 76-77 two piece slip shaft: Remove the bolt on the steering joint at the steering box, slide the shaft back until free of the steering box splines and position out of the way.

4. Remove the steering box by removing the three bolts securing it to the frame. This is a good time to test fit the new box. Before mocking it into position, all Bronco's built from '66-'72 will require the bottom lip of the core support to be manipulated or modified to allow the box to move 3/8" to 1/2" forward on the frame so it can be mounted. Now is a good time to clean and paint this area in preparation for the new box. Inspect the frame for any cracks or damage and repair as needed.

Installation:

5. Before proceeding, be sure the steering box is centered. Place new box on the frame so that the stock holes in the frame align with three of the holes in the steering box. The splined end of the box should point towards the steering shaft. Slide the two rear mounting bolts through the box mounting plate & into the frame, if the third bolt will not slide into the frame, tighten the 1st and 2nd bolts down tight and run a 1/2" drill through the 3rd hole. Once all 3 bolts are in and tight the box should not be making contact with the body anywhere and there should not be a gap between the frame and steering box. If there is some clearancing will need to be done.

6. If you are using the heavy duty reinforcement plate #3230, install it at this time.

Using three 1/2"-13 x 4 1/2" GR5 bolts with 1/2" washers under the heads from the inside of the frame to secure the box to the frame. Fully start all three bolts before tightening any of them. Finish with another 1/2" washers and 1/2" NC Nyloc nut on each. Torque to 60-80 ft lbs. Note: This box has 4 bolt holes. After tightening the three bolts, you can

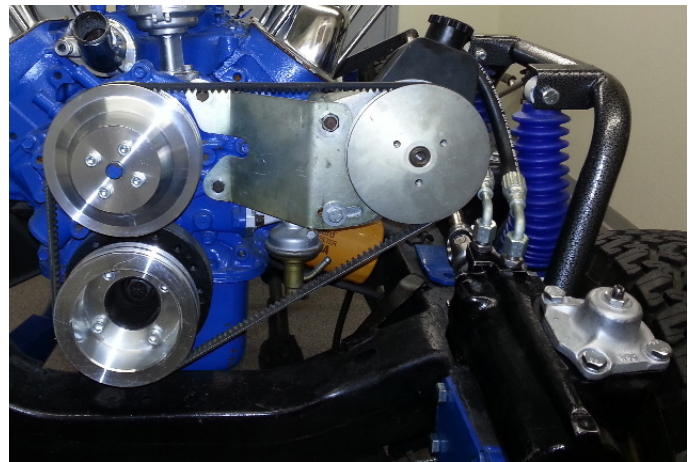

drill the 4th hole through the frame using the box as a template and install the fourth 1/2"-13 x 4 1/2" GR5 bolts with 1/2" washers at this time with the same torque specs.

7. Install the pitman arm on the new box. Make sure the new box is still at center and the arm is mounted pointing back and down. (The quarter spline allow for only one back position). Torque the pitman arm nut to 170-230 ft-lbs.

8. Temporarily slide the new steering u-joint fully over the splines on the input shaft of the new steering box. Remove the locking pliers from under the steering wheel in order to allow the shaft to slide down next to the new u-joint. With the steering box centered, the steering wheel centered and the shaft in its fully down position align the lower shaft along side the new u-joint. Mark the shaft for cutting so that after it is cut it will stick into the u-joint 7/8". Note: The orientation of the flats in the u-joint and mark their corresponding location onto the steering shaft. It is important to carefully mark these locations as they will determine how centered the steering wheel will be after installation. Mark the location of the two Allen head set screws on the shaft as well.

9. Slide the steering shaft up in order to gain access to the lower section for trimming and grinding. It is advisable to remove the shaft completely from the vehicle for this step but it is not necessary. If the shaft is left in the vehicle for trimming and grinding, we suggest securing the shaft with locking pliers placed on the shaft as in step 3. If the vehicle is equipped with a rag joint at the firewall, then temporarily removing the lower steering shaft from the vehicle is recommended.

10. Trim the shaft off at the marked location, making sure not to make it too short (its better to re-cut then to have it too short). At the previously marked locations for the flats, equally grind the shaft sides so that it is no less than 1/2" from flat to flat (side to side). It is best to go slow and take a little at a time as removing too much will cause a loose feel in the steering. Using the steering u-joint as a guide is recommended.

11. At the marked locations for the Allen head setscrews, use a 5/16" drill bit to make indents in the shaft for the setscrews to sit in. This should be just enough for the setscrew to sit in. Note: It may be easier to install the u-joint on the shaft and remark the locations for the setscrew indents. This will also ensure that the shaft is seated properly into the u-joint. **Warning: Do not drill heavily into or all the way through the shaft, as this will weaken it.**

12. If previously removed, reinstall the steering u-joint on the steering box and the shaft into the vehicle. Align the shaft with the u-joint on the steering box so that the flats and setscrew indents align with each other. Fully seat the shaft into the u-joint. Secure the set screws against the shaft and tighten the set screw lock nuts. Secure the setscrew on the steering box input shaft and tighten the set screw lock nut.

Important: For a safer vehicle during a collision it is highly recommended to install a collapsible lower steering shaft #3243 at DuffTuff.com

Pump Installation:

13. Turn the oil-sending unit in a clockwise direction to make clearance for the power steering pump. Turn until it clears the oil filter by about 1/8". If it is too tight to turn, remove the extension from the block and apply thread sealer or Teflon tape on the threads and try again. Be careful not to break this piece off in the block, as it is very fragile, and it is very hard to remove a broken piece from the block.

14. Screw the 7/16" x 7" all thread about 3/8" into the upper hole in the driver side head. Note: if you have a 351W, your heads are higher and you will need our #3160 mounting bracket to correctly position the P/S pump bracket. Bolt the power steering pump loosely to the mounting bracket, starting with the 35 mm bolt and 3/8" washer in the 3 o'clock position, then the 40 mm bolt and 3/8" washer at the 12 o'clock position and then the flat head socket screw at 9 o'clock. Once the bolts are loosely in place, tighten to 20-25 ft. lbs. Note: You may find that temporary removal of the mechanical fan and fan shroud will make the pulley installation easier but it is normally not necessary.

15. Slide the pump and bracket assembly over the all thread and put the new flat bracket over the end of the all thread so that the slotted section of the bracket is at the bottom of the pump assembly. Bolt the bracket into place using the original bolts from the water pump and the 3/8" x 1" adjusting bolt and flat washer.



16. Install the new steering pump belt, reinstall belts and the fan removed earlier. Check belts for proper tension and tighten the 3/8" x1" NC GR5 bolt in the the pump adjusting bracket.

17. Install the pressure and return lines between the pump and the box. The port closest to the steering u-joint is for the return line. We highly recommend installing a power steering cooler at this time, especially those with larger than stock tires and/or locking front differentials. Our steering fluid cooler, Part #3127, is an excellent choice.

18. Fill the power steering pump reservoir with power steering fluid. We highly recommend using synthetic fluid for its improved lubrication and heat dissipation factors. NOTE: Use of any other fluid besides power steering fluid will void the warranty.

19. Cycle the wheels left to right a few times with the engine off. Add fluid as necessary. This may be easier if the front differential is placed on jack stands so that the front tires are off the ground.

20. Start the engine and allow the motor to run for five seconds. Shut off and check and add fluid as necessary.

21. Restart engine and look into reservoir to check the fluid is circulation. If circulation is not present, apply hand over the reservoir to create suction in the pump. If the pump is run for more then 30 seconds with no circulation, damage to the Pressure Plate is possible and will decrease the pumps performance. If circulation is noticeable, cycle steering wheel 3 to 4 times Lock to Lock but not holding at Lock for more than a few seconds. **NOTE: Holding at Lock in the Bleeding stage could heat the pump up and cause damage due to the trapped air and shortage of fluid in the pump.**

22. Check fluid level again and add as necessary.

23. If the pump is operating quietly and there is not aeration of the fluid, then the fluid should be free of air. Once no air is detected replace the reservoir cap. NOTE: This is a hydraulic system just like brakes, and as such, will not function properly with air in the system.

24. Place the vehicle on the ground if previously placed on jack stands. Double-check all fittings, fasteners, belts and fluid.

25. Take a vehicle for a test drive to check the new set up.

26. Check all fittings, fasteners, belts and fluids periodically as well as before and after any off road use.

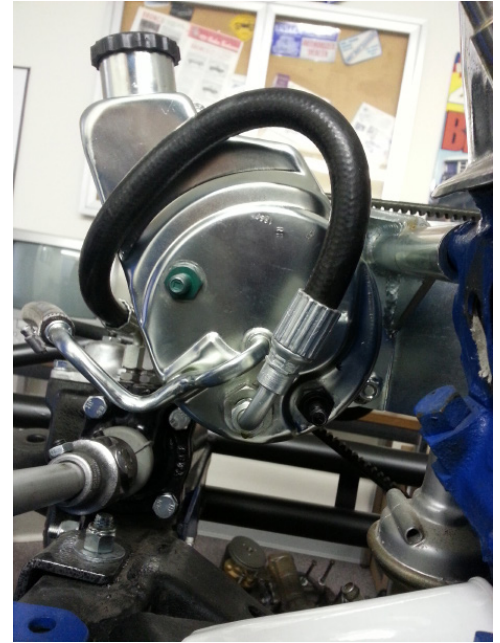

Warning: You have just installed a high performance steering system. It has a very quick turning ratio. We highly recommend having the alignment checked for proper caster at this time. We recommend a minimum of 3° of caster with 4° being even better on power steering equipped 1966-77 Broncos. Not enough caster will result in an extremely quick steering response which, depending on the driver's experience, may or may not be desirable. We highly recommend informing anyone you may allow to drive your vehicle of this modification, as it handles differently than stock.

Other products you may also be interested in:

Early Bronco Dual Sport Heim Steering

Replace your weak, rock-rashed stock or poorly designed aftermarket steering with one of our TUFF new heim joint steering systems!

#5641 '66-'77 Bronco Heim Steer

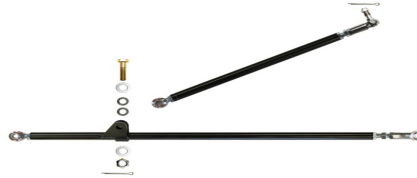

Early Bronco BS Eliminator

This system will combine all of the great parts we offer to create the best, no bumpsteer, system we offer.

Includes:

- Heim Steer Measure Kit
- Heim Steer
- Track Bar Riser Bracket
- Adjustable Trac Bar

#5642 '66-'77 Bump Steer Eliminator

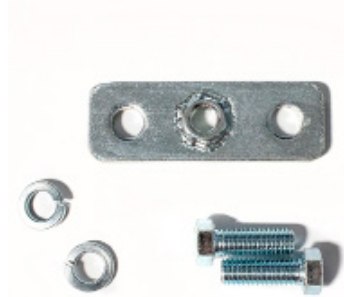

Tapered Heim Stud Kit

Paired with our heim steer system, you no longer need to drill your knuckles. Simply install the tapered end into your knuckle and install your heim over the non-tapered end. Tighten both ends with the 4 supplied castle nuts on both knuckles and install the 4 supplied safety cotter pins.

We offer 2 different stud kits for the most common knuckles used by Bronco owners.

#5647 1 Ton GM or F-150 Knuckles

#5648 Early Bronco Knuckles

OE Early Bronco Pitman Arm

Paired with our heim steer system, you no longer need to drill your knuckles. Simply install the tapered end into your knuckle and install your heim over the non-tapered end. Tighten both ends with the 4 supplied castle nuts on both knuckles and install the 4 supplied safety cotter pins.

We offer 2 different stud kits for the most common knuckles used by Bronco owners.

#5647 1 Ton GM or F-150 Knuckles

#5648 Early Bronco Knuckles

Drop Pitman Arm

A drop pitman arm is not required on all lifted vehicles. If you have already installed your suspension system and are experiencing excessive bump steer or excessive wear on the drag link is apparent then install a drop pitman arm to cure this. Fits '66-'75 without modification. '76-'77 require conversion to T-style steering linkage.

#5473 Drop Pitman Arm



Power Steering Adapter Bracket 351w

This bracket attaches the 302 power steering pump to the 351W heads. They retain stock 302 mounts and use the same belts and pulleys.

#3160 '66-'77 351w PS Adapter Bracket

HD Steering Box Reinforcement Kit

Includes a 3/8" thick reinforcement plate, sleeve and hardware to notch and reinforce the frame in order to utilize the fourth ear on the steering box on our Ultimate Kit or to reinforce the frame on our new Quick Ratio Kit. Highly recommended for anyone running over a 35" tire or ram assist.

#3230 Optional Heavy Duty Mount Kit

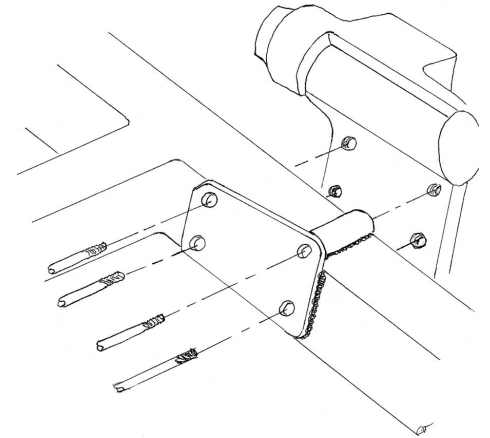

LIMITED WARRANTY

James Duff Inc. warrants our products to the original purchaser to be free from defects in materials and workmanship. Warranty periods begin at the date of purchase and varies by product. Shocks have a limited lifetime warranty. Headers, Radiators and Suspension Products, Power Brake Boosters and Master Cylinders have a one year warranty. Adapters and soft goods such as vinyl and rubber products have a 90 day warranty. All warranties are to the original purchaser with proof of purchase only. Such obligations under this warranty shall be limited to the repair or replacement, at JDI's discretion, of any assembly or part which upon examination by JDI proves to be defective. Any costs of removal, installation, reinstallation or freight charges are expressly excluded from this warranty. This warranty covers only manufacturers defects, and does not cover product finish or damage resulting from abuse, misuse, negligence, racing, alteration, accident or damage in transit.

All returns must be pre-authorized by JDEI and accompanied with a Return Goods Authorization Number (RGA) and a dated proof of purchase. Returns must be made within 90 days of purchase, shipped prepaid, packaged in original cartons to prevent damage in shipment and sent to JDI, 6609 Bronco Ln., Knoxville, TN 37921 Returns without an RGA# will be refused.

This warranty is expressly in lieu of all other warranties, expressed or implied, including the implied warranties of merchantability and fitness for use. This warranty gives you specific legal rights including other rights that vary from state to state. Some states do not allow limitations on how long an implied warranty lasts, or do not allow the exclusion of limitation of incidental or consequential damages, so the above limitations and/or exclusions may not apply to you.

#3226B 4/4 5/25